



## Technical Regulations

### Table of Contents

Part 22	Mandatory Requirements for all Vehicles
Part 23	Principles of Classification
Part 24	Bracket Racing
Part 25	Modified Production
Part 26	Thundersport
Appendix A	Diagrams
Appendix B	Definitions

### **22 Mandatory Requirements for all Vehicles**

- a) The responsibility to ensure that the vehicle and driver's equipment complies with the Regulations and is safe rests solely and at all times with the entrant and driver. The inspection of a vehicle is not a guarantee of the vehicle's safety.
- b) All articles or equipment, which if left loose could present a hazard to the driver, shall be properly secured or removed prior to competition.
- c) All vehicles must be fitted with a body of adequate strength and construction which will provide a compartment for the driver to be effectively isolated from the engine, gearbox, transmission, drive shafts, battery, fuel, oil, road wheels and suspension. There shall be a protective bulkhead between the engine, gas/oil tank(s), battery, and the driver's/passenger's compartment, suitable and sufficient to prevent the passage of flame in the case of a fire. An exception will be made for vehicles fitted with a properly installed FIA approved fuel cell, which contains fire protection inherent in its design. However, they will be subject to the following requirements;
  - i) Vehicles fitted with fuel tanks not supplied as standard equipment by the manufacturer shall be vented to outside of the vehicle. The vent or vent hose shall have a one-way check valve to stop the flow of fuel to the outside of the fuel tank. If the filler hole is situated inside the vehicle, it must be separated from the cockpit by liquid-

tight protection. FIA approved fuel cells (FT3, FT3.5 & FT5) are strongly recommended for all vehicles.

- d) To complete the weight of the vehicle by the use of one or several ballast(s), they shall be strong and of unitary blocks, fixed by means of tools with the possibility to fix seals, placed on the floor of the cockpit.
- e) Roll cages (also referred to as Safety Cages) of approved specification, suitably padded to protect the head and limbs of the driver with six (6) anchoring points are required for all vehicles (Mild Steel or other approved material – Minimum 25mm Outside diameter, 3mm gauge. Galvanized materials are disallowed. It is strongly **recommended** that all competing vehicles comply with FIA roll cage specifications.)
  - i) A roll cage is structural framework made up of a main roll bar and a front roll-bar (or of two lateral roll-bars), their connecting members, one diagonal member, backstays and mounting points. (For example, see drawings 253-3 and 253-4).
  - ii) Safety cage must be designed and made so that, when correctly installed, they substantially reduce body-shell deformation and so reduce the risk of injury to occupants.
  - iii) The essential features of safety cages are sound construction, designed to suit the particular vehicle, adequate mountings and a close fit to the body-shell.
  - iv) Tubes must not vehiclery fluids.
  - v) The safety cage must not unduly impede the entry or exit of the driver.
  - vi) Members may intrude into the occupant's space in passing through the dashboard and front side-trim, as well as through the rear side-trim and rear seats.
  - vii) The rear seat may be folded down.
  - viii) Longitudinally, the safety cage must be entirely contained between the mounting points of the front and rear suspension elements vehiclerying the vertical loads (springs and shock absorbers).
  - ix) Supplementary reinforcements exceeding these limits are authorized between the safety cage and the anchorage points of the rear anti-roll bars on the body-shell.
  - x) A diagonal member is compulsory. Their location must be in accordance with drawings 253-3 to 253-5 and they must be straight, not curved. The attachment points of the diagonal members must be so located that they cannot cause injuries. They may be made removable but must be in place during events For examples of different ways of fitting the compulsory diagonal member see drawings 253-3 to 253-5. The combination of several members is permitted according to drawings 253-3 and 253-5. The

fitting of a second diagonal member, according to drawing 253-4, is **recommended**.

- xi) One or more door-bars (for side protection) longitudinal members must be fitted at the drivers' side of the vehicle (see drawings 253-7, 253-8, 253-12)
- xii) In the case of door-bars in the form of an "X" (cross-struts), it is recommended that the lower attachment points of the cross-struts be fixed directly onto the longitudinal member and that at least one part of the "X" be a single-piece bar.
- xiii) Mounting of roll-cages to the body-shell: Minimum mountings are:
  - 1 for each leg of the main or lateral roll bar.
  - 1 for each of the front roll bar.
  - 1 for each backstay.
- xiv) Diagonal members: At least one diagonal member must be fitted.
- xv) The forward members of the cage shall closely conform to the OEM A-pillar structure OR be adequately gusseted to same or the OEM forward bulkhead.

f) **Roll Cages for Formula and Prototype Vehicles**

All vehicles must have at least two (2) roll over structures. The first roll over structure must be in front of the steering wheel, not more than 10 inches forward of the steering wheel rim, and at least as high as the top of the steering wheel rim.

The second roll over structure must not be less than 20 inches behind the first. It must be high enough for a line extending from the top of the front structure to the top of the rear structure to pass over the driver's helmet when he is seated normally in the vehicle with his helmet on and the seat belt fastened. This second structure behind the seat must be symmetrical about the lengthwise centerline of the vehicle and comply with the following dimensions: The top of the roll bar must be at least two (2) inches (5cm) above the driver's helmet when the driver is seated in a normal driving position.

- g) Safety Belts are mandatory for all vehicles. A safety harness must be used in its homologation configuration without any modifications or removal of parts, and in conformity with the manufacturer's instructions. The required minimum is a five (5)-point harness with 3-inch lap for all occupants. The **recommended** geometrical locations of the anchorage points are shown in drawing N° 253-42.

In the downwards direction, the shoulder straps must be directed towards the rear and must be installed in such a way that they do not make an

angle of more than 45° to the horizontal from the upper rim of the backrest, although it is **recommended** that this angle should not exceed 10°.

The maximum angles in relation to the centerline of the seat are 20° divergent or convergent.

Anchorage points creating a higher angle to the horizontal must not be used unless the seat meets the requirements of the FIA standard. In that case, the shoulder straps of 5-point safety harnesses may be installed on the rear seat lap strap anchorage points originally mounted by the vehicle manufacturer.

Safety harness must not be installed on a seat having no head restraint or having a backrest with integrated head restraint (no opening between backrest and head restraint).

The lap and crotch straps should pass not over the sides of the seat but through the seat, in order to wrap and hold the pelvic region over the greatest possible surface.

The lap straps must fit tightly in the bend between the pelvic crest and the upper thigh. Under no conditions must they be worn over the region of the abdomen.

Holes may be made in the series seat. Vehiclee must be taken that the straps cannot be damaged through chafing against sharp edges.

The shoulder straps may also be fixed to the safety roll cage or to a reinforcement bar by means of a loop, and may also be fixed to the top anchorage points of the rear belts, or be fixed or leaning on a transversal reinforcement welded to the backstays of the roll-bar.

- h) Driver's seat shall be securely fixed and shall be of sound construction.
- i) All vehicles excluding single-seater type vehicles shall have a driver's window net, which shall comply with the following;
  - 1) Be of the ribbon type and cover 70% of the driver's window area.
  - 2) The net shall be permanently attached to the lower edge of the window.
  - 3) The upper attachment shall be of a quick release type.
  - 4) Window Nets are not required if vehicles have driver side window in the up position.
- j) At least one (1) fire extinguisher is mandatory. Dry chemical type must have a minimum capacity of at least 1 kg. Halon type at least 18 oz.
- k) All exhaust shall vent to the outside and away from the body of the vehicle. Exhaust noise shall not exceed 103 db at 10ft measured at a 45 degree angle to the actual point of exit. This shall be measured at 1400 rpm for **Bracket B27/31/37/45** and at 6500 rpm for Modified Production (MP) and Thundersport classes.
- l) The battery shall be securely mounted and insulated.

- m) All vehicles with open type sump breather shall vent into a catch tank with a minimum capacity equivalent to 60% of the engine cc rating. The catch tank shall either be translucent or have a translucent type window.
- n) All vehicles shall be fitted with mirrors that provide driver visibility to the rear of both sides of the vehicle.
- o) All vehicles shall be fitted with a front and a rear-towing eye. The towing eye shall be clearly visible and painted, or the location indicated in, yellow, red or orange.
- p) All vehicles with the exception of formula vehicles shall be fitted with two operating red brake lights. Formula vehicles shall have a red light on the rear clearly visible and shall be illuminated in instances of rain.
- q) Brakes shall be pedal operated working directly on each wheel and in perfect working order.
- r) Suspension and steering shall be of suitable design and be of proper working order. Spherical rod ends shall be retained either by the design of the mounting bracket or by a captive washer.
- s) Hoods shall have two independent fasteners of adequate strength, which simultaneously secure the panel closed.
- t) All vehicles shall have a master circuit breaker, which will cut all electrical power and shall be mounted, in a position easily accessible from outside the vehicle. It shall be clearly marked by the official international marking, a red spark in a white edged blue triangle.
- u) All vehicles shall have an onboard starter, which must be able to start the vehicle at the beginning of the race.
- v) Driver's equipment (garments and helmets) shall comply with the FIA regulations for circuit racing. These are as follows:  
Helmets: FIA 8860-2004, SNELL SA 2000 (not valid after 31/12/2014) SNELL SA 2005, SNELL SA 2010, SFI 31.1, SFI 31.1A or 32.2A, BS6658-type AF/R (not valid after 31/12/2013).  
Clothing: Overalls as well as gloves, long underwear, a balaclava, socks and shoes homologated to the FIA 8856-2000.
- w) The use of Nitrous Oxide (N<sub>2</sub>O) is forbidden in all groups and classes. Only air may be mixed with the fuel as an oxidant. Racing gasoline, gasoline, methanol, gasohol, diesel, ethanol, natural gas and propane are permitted. Nitro methane is prohibited.

- x) Nut, bolts, fasteners, fuses, circuit breakers, gaskets, hoses, bearings, seals, return springs and fittings are free.
- y) Lubricants and Fluids are free unless stated otherwise in class regulations or ASR's.
- z) Identification marks: Each vehicle shall have identification numbers, class letters, or other marks required by the ASR's. Numbers shall be placed on the front and both sides of the vehicle in a legible position. All vehicles shall have identification numbers at least eight inches high with a one and a half to two inch stroke (8" H x 1 1/2"-2" Stroke). All numbers shall have a sharply contrasting background and the distance between two numbers shall be at least as wide as the stroke of the numbers.

Class Designations shall be placed as follows:

**Bracket Classes:** The letter **B** followed by the class number (eg B37).

**Bracket Class 45 Turbocharged:** The letters **B45T**

**Bracket Class 45 Naturally Aspirated:** The letters **B45N**

Modified Production Classes: The Letters **MP** followed by the class number.

**Thundersport Class 1:** The Letters **TS1**.

**Thundersport Class 2:** The Letters **TS2**.

**These markings must be placed on both front doors.**

## Principles of Classification

If these Regulations do not specifically state modifications may be made or specific variations to OEM specifications are permitted, then no additional modifications or variations are permitted. This will be a major factor in the settling of any disputes arising from questions of eligibility. If a vehicle is found not to comply with the technical regulations, it shall be no defense to claim that no performance advantage was obtained.

a) Vehicles shall be divided into three (3) groups:

<b>Bracket Class</b>	<b>(B27, B31, B37, B45)</b>
Modified Production	<b>(MP1, MP2, MP3 &amp; MP4)</b>
<b>Thundersport</b>	<b>(TS1, TS2)</b>

b) In case of forced induction, the nominal cylinder-capacity will be multiplied by 1.7 for petrol engines, by 1.5 for diesel engines and by **1.30** for rotary engines, and the vehicle will pass into the class corresponding to the fictive volume thus obtained.

c) In order to determine the classification of a vehicle using an engine of the NSU Wankel patents (Rotary Engines), the manufacturers claimed cylinder displacement should be increased by a factor of **1.8**. If the same engine also employs a system of forced induction, then the **1.30** factor shall also apply. For example: a Mazda 13B engine rated at 1308 cc would be classified as **2354** cc ( $1308 \times 1.8$ ). If the same engine was turbo charged then the displacement would be **3060** cc ( $1308 \times 1.8 \times 1.30$ ).

d) Improved & Modified Production classes are for vehicles which are generally available for sale to the general public for normal road use.

e) The following chart will establish wheel widths and weights for the classes listed, exclusive of Correction Factors.

### **i) Bracket Classes (B27/33/37/45)**

No Minimum Weight. No Maximum Wheel Width.

### **ii) Modified Production (MP 1, 2, 3 & 4)**

	<b>Engine Capacity</b>	<b>Max. Wheel Width</b>	<b>lbs/cc</b>
<b>MP1</b>	Up to 1600cc	11.0	<b>1.00</b>
<b>MP2</b>	1601cc to 2300cc F/I	<b>12.0</b>	<b>0.90</b>
	1601cc to 2300cc N/A	12.0	<b>0.80</b>
<b>MP3</b>	2301cc to 3200cc F/I	13.0	<b>0.80</b>
	2301cc to 3200cc N/A	<b>13.0</b>	<b>0.70</b>
<b>MP4</b>	3201cc and up F/I	<b>13.0</b>	<b>0.70</b>
	3201cc and up N/A	<b>13.0</b>	<b>0.60</b>

iii) **Thundersport**

	<b>Engine Capacity</b>	<b>Max. Wheel Width</b>	<b>lbs/cc</b>
<b>TS1</b>	<b>0-2300cc</b>	14.0"	<b>0.55</b>
<b>TS2</b>	<b>2301cc - Unlimited</b>	14.0"	<b>0.55</b>

- **Note: All the above MP and TS Forced Induction Engine sizes are classified after the appropriate FI weight factors have been applied.**

**Correction Factors**

1. For MP3, turbocharged two-wheel-drive (2WD) vehicles may subtract 100lbs from their calculated weight.  
e.g. a turbocharged 1600cc 2WD MP3 vehicle may weigh 2196lbs  
 $((1600 \times 1.7 \times .80) + (120 \text{ driver weight}) - 100)$
  2. For **MP4** and TS, turbocharged two-wheel-drive (2WD) vehicles may subtract **200lbs** from their calculated weight.  
e.g. a turbocharged **2000cc 2WD MP4** vehicle may weigh **2300lbs**  
 $((2000 \times 1.7 \times .70) + (120 \text{ driver weight}) - 200)$ .  
e.g. a turbocharged **2000cc** 2WD **TS1** vehicle may weigh **1790lbs**  
 $((2000 \times 1.7 \times .55) + (120 \text{ driver weight}) - 200)$ .
  3. **AWD Forced Induction Vehicles competing in MP1 and MP2 shall add an additional 100lbs to their minimum weight.**
  4. **Movement of Engine and/or Transmission further than 6" of the OEM location for the body style used in the Modified Production and Thundersport Classes shall incur an additional weight penalty of 100 lbs.**
  5. **All Wheel Drive Vehicles, competing in Thundersport and Modified Production shall be limited to maximum rim width of 10"**
  6. **NOTE: Modified Production Vehicles in Classes 1, 2 & 3 that are constructed from tubular metal, will be classified in the next higher class. I.E. a MP1 vehicle with a 1200cc engine would be classified as an MP2 vehicle, but would use the minimum weight for a 1200cc engine racing with the higher class weight factor (MP2).**
- e) The onus is on the competitor to have the vehicle at the legal weight at all times during an event. The legal weight shall be in accordance with the technical regulations for the vehicle as qualified or raced with the driver on board. When called upon to have a vehicle weighed, the following shall apply:

- 1) Vehicles shall be weighed under the supervision of the Technical Inspector or his designate on the official scale for the event.
- 2) The vehicle shall be presented with its gas tank(s) as close to empty as possible.
- 3) All articles which are not an integral part of the vehicle and its equipment shall be removed.
- 4) To complete the weight of the vehicle by ballast, they shall be strong and of unitary blocks, fixed by means of tools with the possibility to fix seals, placed on the floor of the cockpit.
- 5) For the purpose of arriving at 'weight' the weight ratios in the technical regulations shall include an additional 120 pounds. (Thus the weight for an MP1 vehicle shall be the cc X **1.0** + 120 lbs. with the driver on-board).

## **24 Bracket Classes**

- a) **The Spirit of the Rule**  
The purpose of the **Bracket Categories** shall be to provide a category of racing vehicles for competitors who desire to compete in series produced automobiles generally available for purchase by the public, and who additionally desire to improve the performance of these vehicles. The **Bracket** categories is intended for vehicles which are street legal with the exception of exhaust noise. The spirit of the rule shall be respected.
- b) Vehicles entering the **Bracket Classes** must meet the mandatory safety requirements outlined in Section 22 above , with the exception of **B45**, for which no roll cage is required but is **strongly recommended**. **B45** Vehicles are required to be road legal in safe running order, and to have met the necessary requirements as outlined in the **B45** course.
- c) This group is divided into four classes, namely **B27, B31, B37** and **B45**. Racing within this Group is based on the target-time bracket racing concept, with the class name indicating the lower index for each class.
- d) All vehicles entered in this Group must use either D.O.T. or EEC approved tires of any dimension.
- e) Turbocharged vehicles are not required to run restrictors.
- f) All vehicles must retain the O.E.M dashboard. This may be modified, for the installation of additional gauges, and mounting of the roll cage.
- g) Headlights are not mandatory in **Bracket** racing. Headlights if not used shall be replaced with covers of an alternate material be used as long as they closely resembled the OEM units. OEM headlights if used must be taped or covered eliminate the possibility of breakage in a collision.
- h) Vehicles entered in **BC27, 31, 37** are required to have a minimum of one seat only.
- i) **No onboard timing or remote lap timing devices will be allowed during qualifying or races. Radio contact between competitors and crew will not be allowed.**

## **25 Modified Production**

- a) Engine **and/ or** transmission/gearbox shall not be moved more than six (6) inches from the original location. **Movement of these components beyond the above limit shall incur a weight penalty as outlined in Section Principles of Classification (e).**
- b) The overall structure of the vehicle around which are assembled the mechanical components and the bodywork including any structural part of the said structure (i.e. the chassis) may be modified or constructed with tubular steel.
- c) The exhaust system is free.
- d) The Brake and Clutch are free, but the use of vehicle bon brake discs is prohibited.
- e) Active Differentials and Traction Control systems are permitted.
- f) Active suspension systems are not permitted.
- g) Ignition system is free.
- h) Cooling system is free.
- i) Engines are free. (i.e. Nissan engine in a Mazda vehicle). Modifications are free.
- j) Oil cooler(s) shall be mounted within the perimeter of the bodywork and are not visible from above.
- k) Fuel system is free providing that fuel lines shall be of the aviation type lines if the fuel tank is not OEM.
- l) Lubricants and Fluids are free.
- m) Bodywork, Exterior, is free with the following restrictions:
  - The profile of the vehicle when viewed from the side of the automobile is not dramatically changed with the exception of the front and rear air spoilers. All windows and glasses may be replaced with Perspex, Lexan or similar transparent material.
- n) Spoilers and air dams and side skirts are free.
- o) Air ducting is free for the passage of air only and shall not alter the profile of the bodywork when viewed from above.

- p) No part of the vehicle must touch the ground when all the tires on one side are deflated. This test shall be vehicleried out on a flat surface under race conditions (driver on board).
- q) Electrical System
  - i) The make and capacity of the battery cables are free. The battery shall be securely mounted and insulated.
  - ii) All vehicles shall have an onboard starter, which must be able to start the vehicle at the beginning of the race.
- r) Wheels and Tires are as per the chart of wheel / weight specifications for Modified Production however racing slicks and alloy wheels are permitted.

## **26 Thundersport**

- a) Engine, Ignition, Fuel, Cooling, and Lubrication: are free, however all radiators and oil cooler(s) shall be mounted within the perimeter of the bodywork and are not visible from above.
- b) The bodywork shall enclose the complete road wheel when viewed from above.
- c) No active suspension allowed.
- d) Active Differentials and Traction Control are allowed.
- e) No vehiclebon brake discs are allowed.
- f) The make and capacity of the battery cables are free.
- g) The battery shall be securely mounted and insulated.
- h) All vehicles shall have an onboard starter, which must be able to start the vehicle at the beginning of the race.
- i) Wheels and Tires are as per the chart of wheel / weight specifications for Thundersport class; however racing slicks and alloy wheels are permitted.

# APPENDIX A

## Diagrams

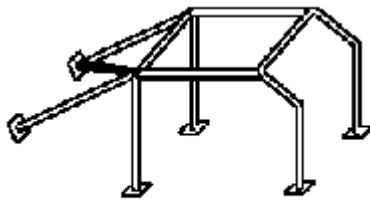

Drawing N° 253-3

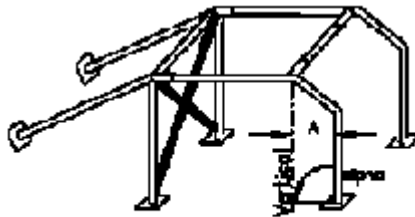

Drawing N° 253-4

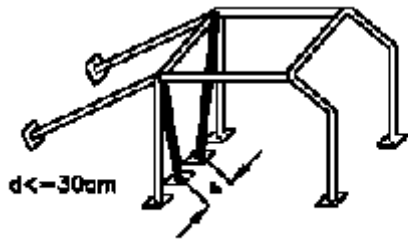

Drawing N° 253-5

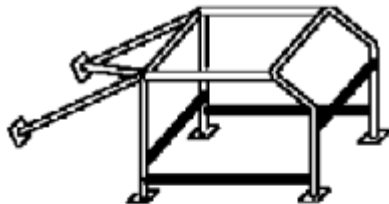

Dessin / Drawing N° 253-7



Dessin / Drawing N° 253-8

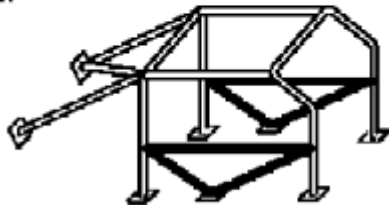

Dessin / Drawing N° 253-12

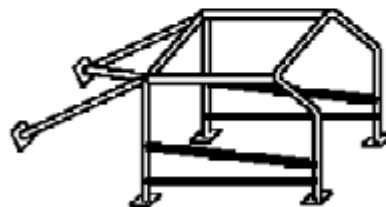

Dessin / Drawing N° 253-17

Cette  
l'entre  
This e  
the d

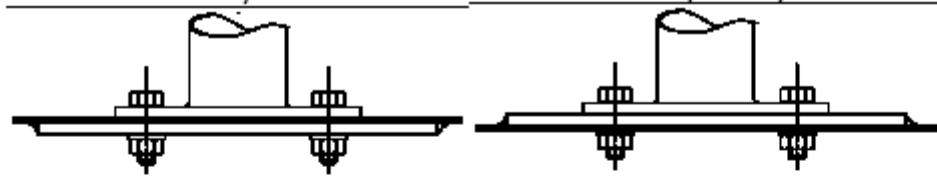

Drawing N°253-18

Drawing N°253-19

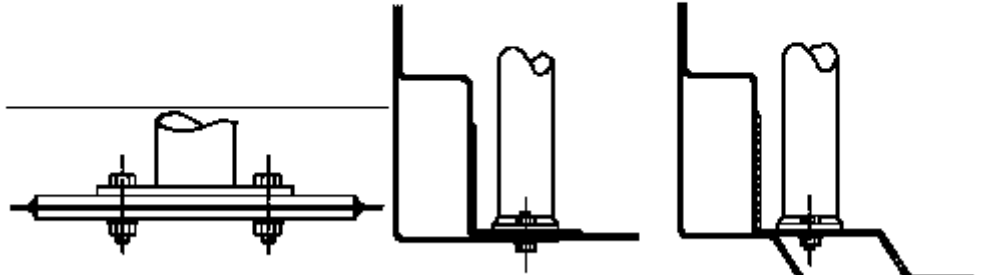

Drawing N°253-20

Drawing N°253-21

Drawing N°253-22

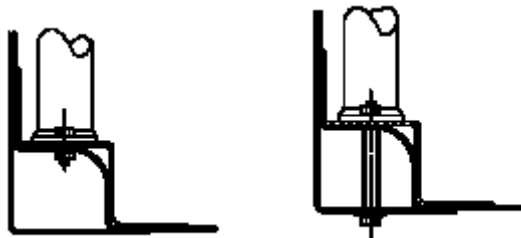

Drawing N°253-23

Drawing N°253-24



Drawing N°253-25

Drawing N°253-28

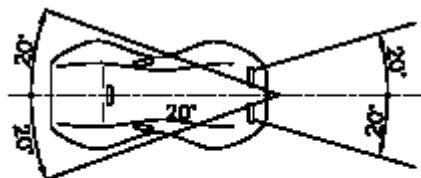
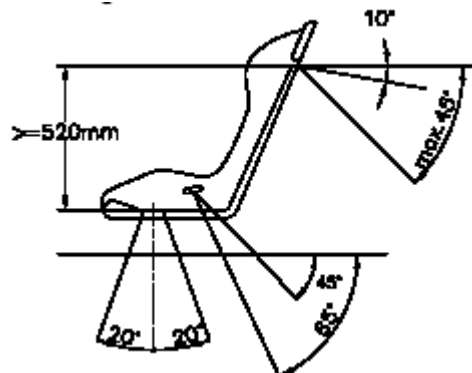

Drawing N° 253-42

## APPENDIX B

### DEFINITIONS

NOTE: Should any of the definitions contained in this Glossary appear to be in conflict with a specific regulation, then the specific regulation will take precedence.

- A-Pillar** - The forward most roof support in a passenger vehicle, which also serves as the side support for the windshield.
- Accelerator Pedal** - A foot-operated device which allows the driver to vary the degree of opening of the induction system throttle(s).
- Accessible** - Capable of being reached without removal of other components.
- Active Suspension** - Automatic ride height and / or roll control by an active system receiving power from a pump or compressor.
- Addition** - To introduce a component not present in the vehicles stock state, or attachment to an existing component.
- Adhesive** - A bonding agent designed to cause two or more components to adhere to each other without fusing them into a single component.
- Aerodynamic Device** - An attachment to, or an integral part of, a vehicle intended to generate atmospheric downforce by the action of air flowing through or around the attachment.
- Aerodynamic Skirts** - Body panels, movable or fixed, at the bottom of the sides of a vehicle's body, which aid in the creation of "ground effects" downforce by ensuring that little air passing under the vehicle can escape at the sides.
- Aeroquip Line** - A brand name, used generically, for a braided metal-covered hose.
- Air Cleaner** - An induction system component intended to filter particulate matter from the incoming air.
- Air Dam** - An air control device at the lower front of a vehicle, intended to divert some of the air which would normally pass under the vehicle when the vehicle is in motion.
- Airfoil** - An aerodynamic device or part of a vehicle which the flow of air over its surface will generate a vertical force by creating a pressure differential between top and bottom surfaces.
- Alloy** - A homogeneous mixture of two or more elements, at least one of which is a metal, and where the resulting material has metallic properties.
- Alter** (verb) - To change a component by modifying.
- Alternator** - A component intended to generate current with which to maintain a proper level of charge in the on-board storage battery.
- Anti-Roll Bar** (Sway bar) - A torsion control device connected to a vehicle's structure, and to moving portions of the suspension, which is intended to control body roll. (Some types of ARB may also serve as a suspension component.)
- Attachment Points** (Suspension) - The locations at which the fixed and moving ends of a shock absorber are mounted and/or the location of the suspension component on the frame or structure of a vehicle.
- Automatic Transmission** - A transmission which is capable of allowing a vehicle to start from a stop without use of a clutch, which may be shifted from gear to gear without use of a clutch, and in which such shifting of gears is accomplished by hydraulic, pneumatic, or electric actuation.
- Axle Housing** - The housing which contains axle shafts and may provide support for wheel hubs.
- Axle Shaft** - A shaft whose purpose is to vehiclery rotational drive from a differential or transaxle to the driven wheels, or simply to support one (1) or two (2) undriven wheel hub(s).
- Axle Tube** - See Axle Housing. Also, the beam connecting the rear wheels on a front wheel drive vehicle.

**Backing Plate** - A braking component used in drum type brake systems, generally to support the brake shoes and wheel cylinder(s) at a wheel.

**Baffle** - A plate or panel in a fluid container, which is designed to inhibit the rapid transfer of the fluid within the container when it is subject to changing dynamic forces.

**Balance** (Verb) - To minimize the dynamic off-axis forces of rotating components, or to equalize the weights of like reciprocating components..

**Ball Joint** - A bearing coupling, generally in suspension or steering systems, consisting of two (2) mating surfaces, one (1) convex and one (1) concave, which permits a range of angular displacements of the two (2) attached shafts over a prescribed range.

**Ballast** - Non-functional mass fastened inside a vehicle to increase the weight of the vehicle.

**Battery** (Storage) - An on-board electrical storage component which may be used to activate electrical devices or systems, such as starter, ignition, etc.

**Battery Box** - A covered container for an on-board storage battery.

**Beam Axle** - A solid, non-rotating axle connecting the undriven wheels of a vehicle.

**Bearing** - A mechanical component provided to allow connected parts to move with respect to one another in a manner consistent with durability and minimal friction.

**Bias Ply Construction** - A tire construction in which the structural plies of the main vehiclecass form an angle considerably greater than zero relative to a cross section of the tire.

**Block** - The elemental component of a reciprocating engine which contains at least the cylinder location(s) and the crankshaft mounting points.

**Blueprinting** - The practice of engine improvement achieved by the use of selected standard parts and/or by optimizing the factory machined surfaces of stock engine components to achieve the most advantageous specifications within the normal range as defined by the manufacturer for that engine.

Within the above definition of blueprinting, any procedures that involve the following are not permitted unless specifically authorized:

- a) The addition of material of any kind to any component (this includes, but is not limited to, the addition of sleeves/bushings and the application of anti-friction, oil shedding and thermal barrier/retention coatings).
- b) The machining, tooling or any other physical or chemical modification (including shot blasting) of any surface that was not originally a factory machined surface. Glass or other media blasting for cleaning purposes only is allowed as long as it does not remove or modify the base material of the original part.
- c) Mixing/matching of parts from any other year, make, model or type of vehicle or engine.
- d) Balancing procedures that involve spot machining of all rotating and/or reciprocating parts (i.e. one rod/piston assembly must remain untouched).

Note: Under no circumstances may any factory specification be exceeded as a result of any permitted blueprinting operation(s) (i.e. compression ratio, valve lift, bore, stroke, etc.).

**Body** - All parts of the vehicle licked by the airstream and situated above the belly-pan/floor with exception of the roll bar or cage. For Formula and Sports Racing vehicles, further exceptions are those units definitely associated with the function of the engine or transmission.

**Body Panel** - A replaceable section of the body.

**Bodywork** - See Body.

**Bolt Pattern** - The arrangement of bolts or other fasteners used to join two (2) components.

**Boost** - The degree of induction pressurizing in a turbo/supercharged engine.

**Bore** - The diameter of a cylinder.

**Brake Light** - A signaling light mounted on the rear of the vehicle, which may be actuated only by driver braking actions.

**Brake Lining/Pad** - Replaceable friction material which accomplishes braking action by making rubbing contact with the brake drum or rotor.

**Brake Rotor** - The disc component of a braking system, which is attached to a wheel hub and provides a friction surface for braking actions.

**Brake Rotor Hat** - The integral part of a brake rotor or a separate component that locates and provides attachment for the brake rotor to the hub.

**Braking System** - A system, including hydraulic and mechanical components, which allows the driver to reduce the velocity of a vehicle.

**Breather Vent** - An aperture which allows the flow of air into or out of an enclosure.

**Bulb** - A lighting system component which contains the actual light emitting element(s).

**Bulkhead** - A partition separating compartments.

**Bumper** - A semi-rigid attachment to the structure of a vehicle at the front or rear, which is intended to absorb a portion of low speed front or rear collision forces.

**Bushing/Bush** - A sleeve or tubular insert, whose purpose is to reduce the dimension(s) of an existing hole. A protective liner that cushions noise, friction, or movement such as a rod end or spherical bearing.

**C-Pillar** - The body roof support bordering on the rear window or hatch.

**Caliper** - A braking system component which is the disc brake equivalent of a wheel cylinder, and converts hydraulic pressure into mechanical braking force at a wheel.

**Camber** - The angle of a wheel relative to true vertical. Negative camber implies that the top of the wheel is closer than the bottom to the vehicle's centerline.

**Camber Compensator** - A wheel location device designed to control the wheel camber under varying conditions of bump/rebound.

**Camshaft** - An engine component, driven by the crankshaft, whose function is to actuate the valves, and often, to drive other engine components.

**Vehicleburetor** - The component of a non-fuel injection induction system which achieves the mixing of fuel and air to create a combustible mixture.

**Caster** - The angle which the swivel axis of a steered wheel makes with the vertical in the fore/aft direction..

**Catch Tank** - A container with the purpose of collecting liquid, generally lubricant, vented from an engine, transmission, transaxle, or differential and preventing the loss, from the vehicle, of the liquid.

**cc** - Cubic centimeter (a unit of volume).

**Centerline** - A line coincident with the axis of rotational symmetry of a component.

**Clutch** - A device whose function is to permit the driver to engage/disengage a power coupling between the engine and the transmission or transaxle.

**Cockpit** - The driver/passenger volume within a vehicle in which driver control devices, gauges, and seating are provided..

**Coil-Over Shock** - A tubular shock absorber which contains top and bottom mounting locations for a coaxial coil spring, and is used with such a spring supporting the weight of the vehicle.

**Component** - A constituent part of an assembly.

**Compression Ratio** - Reciprocating engines: the ratio of the sum of swept plus unswept volumes to the unswept volume. Rotary engines: the ratio of the largest to the smallest volume of the working chamber.

**Connecting Rod** - A component physically connecting a piston to a crankshaft in such a way as to convert the rotary motion of the crankshaft to a reciprocating motion of the piston.

**Constant-Velocity Joint** - A type of universal joint in which the angular velocities of input and output shafts are held approximately equal.

**Cool Suit** - A driver's safety suit which has provision to be cooled by a circulating liquid.

**Cooling System** - Those components directly associated with the cooling of an engine, including any hoses, fans, radiators, etc.

**Crankshaft** - The rotating engine component which, driven by piston/connecting rod assemblies, transmits, for external coupling, the torque resulting from the combustion process.

**Curvature** - The dimension defined by the maximum distance between a curving surface and the straight line between its ends..

**Dash board** - See instrument panel..

**Differential** - A gear assembly, physically separate from the transmission, whose purpose is to reduce the rotational velocity transmitted from the engine/gearbox, while providing a division of driving force to two (2) wheels.

**Differential Housing** - The housing in which the differential (final drive) gears are mounted.

**Disc Brake** - A braking system which relies on the friction between a suitable material in the form of a "pad" and a rotating disc to supply the braking force at a wheel.

**Displacement (Engine)** - Reciprocating engine: the swept volume of one (1) cylinder times the number of cylinders. Rotary engine: the difference between the largest and smallest volumes of the working chamber, times the number of lobes, times the number of rotors.

**D.O.T.** – Department of Transportation (Tyre Approval Marking)

**Door Panel** - The inner shell of a door which normally supports the trim.

**Dowel** - A tubular or cylindrical pin, the sole purpose of which is to make positive location of two assembled components possible.

**Drive Shaft** - The mechanical drive train coupling between transmission and differential, which may allow an angular displacement of the driving and driven axes by the use of universal, constant velocity, or flex joints.

**Drive Train** - Those components in a vehicle which produce and convey the driving power to the ground, and the housings containing these parts.

**Dry Sump** - An engine lubrication system in which the residual lubricant is pumped to an external storage tank by a "scavenge pump," and an additional pump or pumps return a supply of pressurized lubricant to the engine from the storage tank.

**Dry Tire** - A race tire, often with groove-less tread, intended strictly for use in competition under dry conditions..

**Duct/Ducting** - A tube or passage for conveying a material, usually air.

**Dust Shield** - A cover intended to protect disc brake components from mud, dirt, etc.

**Eccentric Shaft** - The analog of a crankshaft in a rotary engine, the shaft driven by the actions of the rotor.

**End Plate** - An air control panel mounted at each end and perpendicular to a wing, intended to maximize the efficiency of the wing by preventing spillage of flowing air at the ends.

**Engine** - The primary power plant of a vehicle, including all physically attached ancillary components necessary for power production.

**Engine Air Box** - An induction system attachment, generally part of the bodywork, which ducts air from an opening protruding into the airstream to the induction system intake(s).

**Engine Case** - See rotor housing and/or block.

**Engine Compartment** - The loosely defined volume, nominally enclosed by panels on top and sides, which is the normal location of the engine in a vehicle.

**Engine Mount** - A passive mechanical coupling used to support the weight of an engine at its attachment points to the structure of a vehicle.

**Engine Position** – A. V8, V6, and V4 engines shall align the center of the foremost spark plug hole in line with the front axle spindles.

B. In-line six (6) cylinder engines shall align the center of the first spark plug hole (from the front) in line with the front axle spindles.

C. In-line four (4) cylinder engines shall align the center of the first spark plug hole (from the front) in line with the front axle spindles.

D. Rotary engines shall align the forward most spark plug hole in line with front axle spindles.

E. The engine may be rotated about the crankshaft centerline (lean over) a maximum of fifteen (15) degrees unless otherwise noted and shall not cause hood bulges.

**Engine Steady Bar** (Torque suppressor) - A constraining beam or rod intended to resist the tendency of an engine to rotate on its mounts in reaction to torque forces.

**Exhaust Pipe** - A duct of unspecified dimensions, whose function is to convey exhaust products toward the rear of a vehicle and away from the driver.

**Exhaust System** - A passive system, whose components serve to convey the exhaust of an engine past the driver and away from the vehicle.

**Fasteners** – Any mechanism which serves no other purposes than to cause a component to maintain a fixed position (i.e. bolt, nut, screw, etc.).

**Fender** - The body panel covering a road wheel assembly.

**Fender Flare** - An attachment to an existing fender which extends the fender outward so as to more completely cover the tire within.

**Fender Skirt** - A removable fender extension which partially closes the wheel opening, smoothing the air flow in this region.

**Ferrous** - An alloy containing iron.

**Filler Cap** - A closure which prevents the loss of fuel from the filler neck/hose when the vehicle is in use, but which may be removed for refueling.

**Filler Neck/Hose** - The attachment to a fuel cell/tank through which fuel is supplied from a source external to the vehicle.

**Final Drive Ratio** - The ratio of input to output shaft motions in a final drive or differential.

**Fire Extinguisher** - An on-board container of specified capacity charged with approved fire extinguishing material which provides the driver or others with the capability to control small fires.

See Section 22, J

**Fire System** - An on-board fire extinguishing system designed to be activated in the event of fire, whose purpose is to extinguish or retard the fire, thus providing a measure of protection for driver and vehicle.

**Firewall** - A metal panel separating and protecting the driver/passenger compartment from the engine compartment, preventing the passage of flame and debris. Metal ducts may penetrate the firewall, but must begin and end outside of the driver/passenger compartment. No intakes are allowed in the firewall.

**Flare** (Verb) - 1. To extend by extrusion or attachment a fender so as to more completely cover the tire mounted within (Noun) - 2. Extruded end of a pipe or tube.

**Flat Bottom** - A race vehicle construction in which the underside of the vehicle is nominally flat and contains no “ground effects” shaping or ducting.

**Floor Pan** - The section(s) of a vehicle normally used as a supporting platform for seats and to physically separate the interior (cockpit) area from the underside of the vehicle.

**Fluid** - Any material which readily flows at the specified temperature, e.g., liquids and gases at room temperature.

**Flywheel** - An engine attachment whose normal functions are to provide a gear appropriate for starter engagement, to provide a friction drive surface and attachment points for a clutch pressure plate, and to smooth the flow of power.

**Frame** - The minimal configuration of a vehicle necessary to contain all running gear and to provide support for the body. Not present on “frameless” or “unibody” vehicles.

**Fuel** - The chemical mixture which, when mixed with air, is burned in an engine to produce power.

**Fuel Cell** - A crash-resistant container for the on-board fuel supply of a vehicle.

**Fuel Line** - A hose or tube which conveys fuel from one point to another.

**Fuel Tank** - A conventional OEM container, not of the safety fuel cell type, for the on-board fuel supply of a vehicle.

**Gusset** - A brace generally formed by attaching, by welding, a plate at or near the junction of two structural beams or tubes, providing reinforcement particularly in the plane including the tubes and the plate.

**Hand Brake** - A braking system component causing a braking action on one (1) or more wheels, or on another part of the drive train, which may be actuated and locked in the engaged position by the driver.

**Head and Neck Restraint** - A protection device which attaches to the helmet and is intended to decrease neck stresses and forward head movement during an impact.

**Kill Switch** - See Master Switch.

**Limited Slip Differential** - A differential which is designed in such a way as to overcome the normal action of a differential to apply most of the available torque to the least loaded wheel, and instead to apply a significant portion of the torque to the most loaded wheel.

**Lubricant** - A substance which, when interposed between components moving with respect to each other, reduces friction and promotes durability. (see 9.3.36).

**Master Cylinder** - A hydraulic component of the braking system which produce positive pressure in the hydraulic lines on the application of mechanical force.

**Master Switch** - A safety switch which can be actuated by the driver or other to disable all operating electrical functions, without disconnecting the electrical supply to any fire system present.

**Metal** - An element that forms metallic bonds between its atoms, is usually shiny, is usually ductile and malleable, usually has a high melting point, is usually hard, and conducts electricity and heat well.

**Mirror (Rear View)** - A reflective device whose sole purpose is to enable the driver's field of vision to extend in a rearward direction.

**Modify/Modification** - To change a component *from stock*.

**Monocoque** - A frameless construction in which the main structure of a vehicle is composed of a permanent assembly of panels to which the running gear, suspension and body are attached.

**Muffler** - A component, whose function is to reduce the sound level from an exhaust system..

**O E M** - Original Equipment Manufacturer..

**Orientation** - Alignment relative to its major axis.

**Overhang** - The distance which the end of the bodywork extends away from the wheels at the referenced end of the vehicle.

**Pickup point (Suspension)** – The location of attachment of a suspension component on the frame or structure of the vehicle. Pickup point is also referred to as “pivot axis.”

**Piston Ring** - A reciprocating engine component which, when mounted on a piston, provides either sealing or oil control functions when the engine is in operation.

**Plenum** - An induction system chamber generally interposed between vehicleburetor(s) or air intake(s) and ducts feeding ports.

**Power Brakes** - A braking system in which the driver-initiated mechanical force acting on a master cylinder is assisted by a servo mechanism, generally derived from manifold vacuum.

**Power Steering** - A steering system in which the driver-initiated force acting on the steering gears is assisted by a servo mechanism, usually involving an engine-driven hydraulic pump.

**Pressure Plate** - The clutch assembly component which provides the force necessary to couple the engine to the next component in the drive train through friction surfaces.

**Profile** (Verb) - To measure or to reshape the contour of a camshaft lobe, rocker arm or similar component.

**Proportioning Valve** - A braking system component intended to allow adjustment of the hydraulic pressures available in separate branches of the system (e.g., front/rear).

**Qualifier** - (a) One who receives a time, or (b) One who is waived into a race by the Chief Steward and starts the race.

**Rack and Pinion** - A type of steering system, or the gear components thereof, in which the rotary motions of a pinion gear attached to the steering shaft act on a rack, or linear g

**Radiator (Cooler)** - A heat exchanger intended to remove heat from engine or gear fluids.

**Radius** (Verb) - To contour an abrupt edge on a component by increasing the radius of the transition.

**Rain Tire** - A racing tire intended solely for competition in wet conditions.

**Ratio (Gear)** - The number of rotations of the drive shaft which produces one (1) rotation of the driven shaft(s).

**Removal** - To take off a component.

**Repair** (Verb) - To remove the effect(s) of accidental damage to a component, returning it to original or legally modified dimensions and function.

**Ride Height** - The distance from level ground to the specified portion of the vehicle, with the tires, wheels, air pressure, etc., as normally raced.

**Rim Width** - The distance between the opposing lateral sides of a road wheel in the region where the bead of a tire seats. Measuring method per tire and rim association standard.

**Rocker Panel** - The body panel closest to the ground extending along either outer side of a vehicle between the wheels.

**Rod End** - A load-bearing threaded mechanical coupling with angular freedom of the relative axes and which allows rotation of the inner portion with respect to the outer, i.e. heim joint.

**Roll Bar** - A safety device designed to protect the driver from injury in the event of a roll over accident.

**Roll Cage** - An extension of a minimal roll bar, designed to protect the driver from injury from accidental forces in several directions.

**Rotary Engine** - A non-reciprocating engine of the NSU-Wankel type.

**Rotary Engine Rotor** - The main rotating component of a rotary engine, which essentially accomplishes the compression, power delivery and exhaust functions of a reciprocating engine in constrained rotation in a specially shaped housing.

**Rub Strip** - Expendable material added to bottom of a vehicle to prevent contact with the road surface from damaging non-expendable portions of the vehicle.

**Scattershield** - A stationary safety device intended to protect the driver in the event of catastrophic clutch/flywheel failure.

**Seat Belt** - A safety strap, generally containing the attachment/release mechanism for all other safety straps, intended to restrain the driver against forces tending to move the driver.

**Section Width** - The lateral cross section of a tire, sidewall to sidewall.

**Shock Absorber** - A device intended to dampen the actions of road springs.

**Shoulder Harness** - A safety strap assembly intended to restrain the driver's upper body under conditions of rapid reduction of forward velocity. See Section 9.3.18.

**Side Marker Light** - A small light fixture normally mounted on the side of a fender, which is intended to make the vehicle more readily visible from the side under appropriate conditions.

**Signal Light** - A light fixture used to signal turns or, in some cases, stops.

**Slave Cylinder** - A hydraulic system component which achieves the conversion of hydraulic pressure to mechanical force, usually to accomplish a disengagement of the clutch.

**Space Frame** - An automotive frame constructed of multiple small tubes See also Tube Frame.

**Spark Plug** - An engine component which, by means of high voltage supplied by an ignition system, initiates the combustion of the air/fuel mixture.

**Specification** - A detailed presentation of parameters which determine the performance or suitability of a system or assembly of systems to accomplish design goals.

**Spherical Bearing** - A load-bearing connector in which the central portion is convex and the outer portion is concave, allowing both angular displacements of the axes and relative rotation.

**Spoiler** - A panel attached to the body of a vehicle at the front or rear, intended to alter the airflow around or under that end of the vehicle when in motion.

**Starter (Self Starter)** - An electrical device which is used to initiate normal engine operation by converting electrical energy into mechanical rotation of the engine.

**Steering** - The mechanical system of components that allow a wheel to be turned side to side to follow the desired course of its driver.

**Sub-frame/Cross Member** - A component attached to the frame or structure of a vehicle in order to augment its strength while at the same time serving as a platform for mounting suspension and drive train components.

**Substitution** - To remove a component and replace it with another.

**Surround** - To enclose on all sides.

**Suspension** - A mechanical system of components controlling vertical motion and connecting the axle housing and wheels to the chassis of a vehicle.

**Suspension Bushing** - A hollow cylindrical mounting component which acts as a bearing, allowing constrained motion, between a suspension component and attachment point.

**Track** - The distance between the center of the rims of two wheels at one end of a vehicle, with any angular adjustments at normal settings and steered wheels in the straight ahead position.

**Transaxle** - A component containing the mechanisms necessary to achieve the combined functions of a transmission and a differential.

**Translucent** - Permitting the passage of a reasonable amount of visible light. In the case of fluid containers, permitting the visual assessment of fluid levels by observing these through the container.

**Transmission (Gearbox)** - An assembly of driver-selectable gears in an independent housing, located between the engine and driven wheels, whose function is to alter the rotational velocity reaching the wheels.

**Transparent** - Offering very little resistance to the passage of visible light, suitable for use in the line of sight.

**Transverse Engine** - An engine located in a vehicle such that the crankshaft centerline is nominally perpendicular to the normal direction of vehicle motion.

**Tub** - The central contiguous assembly of stressed panels which form the basic structure of a frameless vehicle.

**Tub-based (non tube-frame) Vehicle** - A non-tube frame vehicle has a stock floor pan, firewall, door pillars, sills, windshields conforming to stock profile, and window frames, etc.

**Tube Frame Vehicle** - A vehicle intended solely for racing, whose main structure or frame is fabricated from an assembly of tubes welded into the desired configuration.

**Turbocharger** - An induction system compressor component, driven by exhaust gases from the engine, which provides forced flow of the fuel/air mixture into the engine by means of positive pressure.

**Unibody** - A type of construction in which the main vehicle structure is fabricated from an assembly of panels and reinforcements, permanently fastened together, generally by welding, into a single unit.

**Visible** - Capable of being seen, perceptible to the eye, apparent, evident.

**Welding** - The process of fusing one or more components into a single unit by means other than adhesives or fasteners (i.e. TIG, MIG, soldering, brazing, etc.).

**Wheel** - Flange and Rim.

**Wheel Spacer** - A plate of unspecified thickness or material which is mounted between a road wheel and hub to increase the distance from the inside of the wheel to the hub, thereby increasing track.

**Wheelbase** - The distance between the front and rear axle centerlines of a vehicle, with the front wheels in the straight ahead position.

**Windows:**

A. **Door or Side** - The opening where the window normally is raised or lowered in a door.

Does not include a "vent" window whether fixed or movable.

B. **Quarter (1/4)** - On a 2-door or 4-door vehicle, the window to the rear of the rearmost door.

Such windows are not generally raised or lowered, but they may be hinged and open to the rear. Quarter windows are not "rear" windows.

C. **Rear** - Rear windows are positioned at right angles to the longitudinal axis of the vehicle.

**Windshield (Windscreen)** - An attachment to the bodywork of a vehicle intended to divert the flow of air from forward motion without obstructing forward vision.

**Windshield Pillar** - A body component which extends nominally upward from the cowl area, forming one supporting attachment for the windshield.

**Wing** - An aerodynamic attachment to the structure of a vehicle specifically intended to generate downforce from the action of air flowing over the upper and lower surfaces, creating a pressure differential.

**Wiring Harness** - Bundles of electrical wires which provide the electrical links in a vehicle.

**Wishbone Type Suspension.** - A form of suspension in which the lower (and often upper) locating links are in the form of a wishbone or "A-frame", and provide the lateral and at least a portion of the fore/aft wheel location.